

## THREE AXES POSITIONER



## PV SERIES

The company was founded in the year 1987. In the beginning, we only supplied machines for the Spanish market. Step by step, we started to expand our activities to other European countries and, today, we are exporting our hydraulic presses to more than 20 countries worldwide.

# GARNET



## LOADING CAPACITIES:

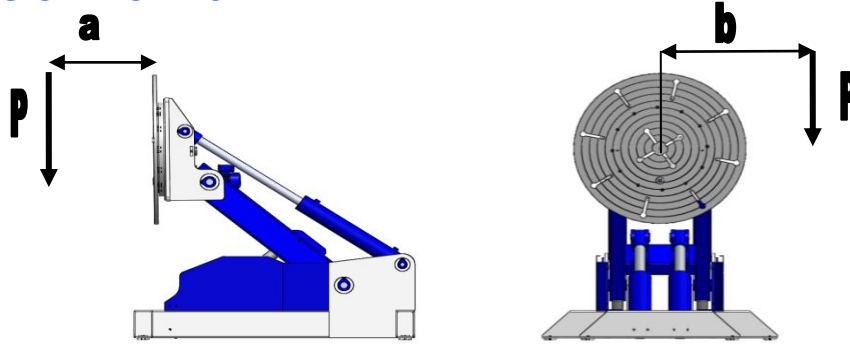

<b>PV-2000</b>	<b>P (kg)*</b>	2000	1800	1700	1500	1300	1200	1100	1000
	<b>a (mm)*</b>	400	450	500	600	700	800	900	1000
	<b>b (mm)*</b>	90	100	105	115	130	140	155	175
<b>PV-4500</b>	<b>P (kg)*</b>	4500	3900	3500	3000	2500	2300	2000	1500
	<b>a (mm)*</b>	500	550	600	700	900	1000	1200	1500
	<b>b (mm)*</b>	75	85	95	110	130	140	160	210
<b>PV-7000</b>	<b>P (kg)*</b>	7000	6100	5400	4200	3300	2700	2100	1600
	<b>a (mm)*</b>	500	550	600	750	1000	1200	1500	2000
	<b>b (mm)*</b>	85	95	110	140	165	220	280	350
<b>PV-10000</b>	<b>P (kg)*</b>	10000	8800	7300	6000	4700	4200	2750	2200
	<b>a (mm)*</b>	500	550	600	700	1000	1200	1500	2000
	<b>b (mm)*</b>	75	90	105	130	165	185	200	310

## TECHNICAL FEATURES:

	<b>PV-2000</b>	<b>PV-4500</b>	<b>PV-7000</b>	<b>PV-10000</b>
Max. Capacity (Kg)	2000	4500	7000	10000
Motor power (kw)	4 + 0,5	5.5 + 0,5	7.5 + 0,75	9.5 + 0,75
Table dimensions: E (mm)	Ø800	Ø1100	Ø1500	Ø1500
Table tilting $\beta$ (degree)	0-92	0-92	0-92	0-92
Ascent time of the table (s)	18	18	50	50
Descent time of the table (s)	12	12	34	34
Table rotation speed (rpm)	1,2-1,8	0,8-1,2	0,8-1,2	0,7-1,0
Maximum height with vertical table: A (mm)	1350	1400	2350	2550
Maximum height with horizontal table: B (mm)	1450	1520	2500	2680
Minimum height with horizontal table: B' (mm)	750	770	850	975
Max. length : C (mm)	1925	1985	3250	3400
Max. width: D (mm)	1400	1500	2000	2100
Weight (Kg)	1200	1500	2800	3100

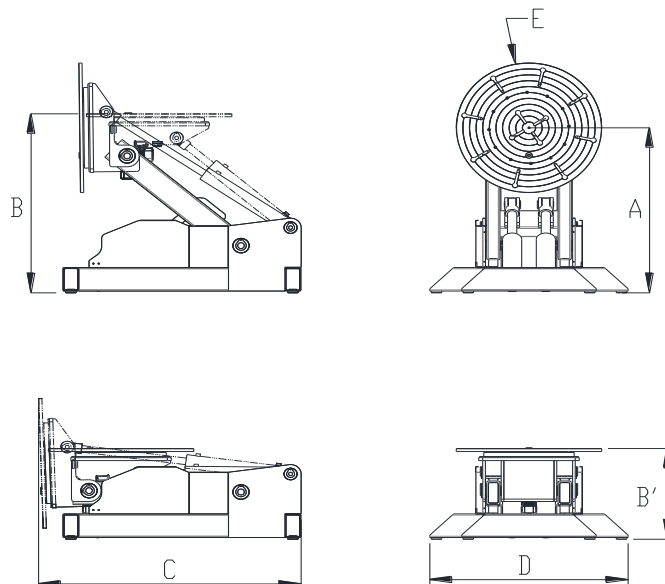



These positioners are designed to carry out welding, adjusting and assembly operations in optimal security conditions. The innovative characteristics of this positioner, truly unique in its field because of its capabilities, offer the possibility to execute the following operations:

- Continuous and bidirectional rotation
- Plate inclination
- Plate elevation

The rotation is carried out through a reducer motor device with a slew ring. Inclination and elevation is executed through oleo-dynamic cylinders.

The infinite working positions it offers, makes the machine operator work in a secure and ergonomic position. This reduces remarkably the working time and avoids depending on auxiliary elevation elements

Our standard production is available in four carrying capacities, 2000 kg, 4500 kg, 7000 kg and 10000 kg. Under request we can make other capacities.

**Lower bed:** designed for a highly steady behaviour and put together by highly resistant structural profiles that allow the execution of elevation, inclination and rotation of big workpieces and weights in secure conditions.

**Plate with rotation device:** It permits the continuous and the bidirectional rotation of the workpiece that is being handled. The plate is made of high elastic limit sheet metal and has well positioned holes and slots to achieve a secure fixation of the workpiece through rapid attachment accessories. The slew ring acts as a joint element between the lower bed and the workpiece holder plate.

**Maneuver:** The machine is supplied with a control button bar that permits executing all the maneuvers. The button bar disposes of a regulator such as a potentiometer to easily control the speed of the plate rotation.

**ELEVATION AND INCLINATION.** Oleo-dynamic mechanism that works at a constant speed. The infinite combinations of both movements permit operate in an optimal way during the adjustment and welding maneuvers and/or during the assembly in multiple applications.

**ROTATION.** The mechanism disposes of a progressive starting and stopping system.

## OPTIONAL EQUIPMENT

---

- Elevation and inclination speed control.
- Wireless control system, through radio frequency.
- Weight system.
- Automatic stop system when “not in use”.
- Personalized and intelligent load attaching system.
- MEMORY device, permits the saving of multiple positions for repetitive works

**WE ARE SPECIALIZED IN THE FABRICATION OF POSITIONERS WITH SPECIAL FEATURES, MEASUREMENTS AND CAPACITIES IN ORDER TO MEET THE REQUIREMENTS OF EACH USER.**