

CATALOGUE 2026

# HYDRAULIC INSERTION PRESSES

ANALOG AND DIGITAL

[www.hidrogarne.com](http://www.hidrogarne.com)



## ¿Why choose Hidrogarne?

We work closely with our customers to help them achieve their production goals, supported by solid experience and recognized know-how, as well as innovative and technologically advanced solutions.



More than 39 years of experience support our track record in the hydraulic press manufacturing sector.



Hidrogarne stands for quality, reliability, guarantee and innovation in the manufacture of hydraulic presses.



We design and manufacture hydraulic presses custom-built to meet the specific requirements of each customer.



We provide comprehensive support throughout the entire process, from machine definition and engineering to installation and after-sales service.



International presence: we export to more than 25 countries worldwide, consolidating our brand in the main international markets.



We apply strict quality standards at every stage of the manufacturing process. All our presses are supplied with a 2-year warranty.

# INSERTING MACHINES

**STANDARD DESCRIPTION:**

HIDROGARNE **hydraulic insertion presses** are designed for inserting and clinching operations, offering robustness, precision, and reliability. They are compact, space-saving, fully hydraulic units that ensure precise insertion at any point along the punch stroke.

They allow clinching operations on thicknesses from 1 to 6 mm and the insertion of all types of inserts in materials such as copper, aluminum, carbon steel, and stainless steel. They are available with insertion capacities of 6, 10, and 15 tons.

**OPTIONAL:**

- Automatic insert feeding system (NC models)
- 4-station turret system with automatic work position detection (NC models)
- High-efficiency inverter system (start-stop)
- Laser pointer
- Brush table

**TECHICAL FEATURES:**

MODEL	Power	Motor power	Adjustable stroke	Throat depth	Working height	Width	Depth	Height	Weight
	t	kw	mm	mm	mm	mm	mm	mm	kg
60 ANALOG 60 NC DIGITAL	6	3	0-80	500	1090	610	780	1800	550
100 ANALOG 100 NC DIGITAL	10	3	0-80	650	1180	610	780	1900	700
150 ANALOG 150 NC DIGITAL	15	4	0-80	500	1033	540	960	1700	825

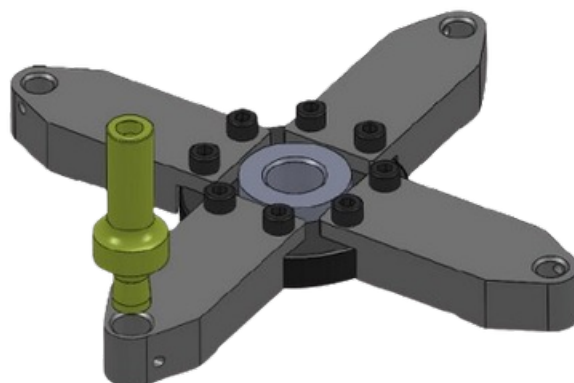

4-STATION TURRET SYSTEM WITH AUTOMATIC WORK POSITION DETECTION

# ANALOG INSERTION PRESSES

Hydraulic **analog insertion presses** are designed for standard production applications and repetitive work, where ease of use and reliability are prioritized.

They incorporate a dual integrated safety system, operation by means of a dual electric safety pedal, manual pressure regulation, and return stroke adjustment of the punch, allowing fast and efficient setup of the insertion process.



*Model 60 – Standard analog version, 6-ton capacity*



# DIGITAL INSERTION PRESSES

Digital hydraulic insertion presses are intended for applications requiring **greater process control and precision**.

They incorporate integrated **software and a 4" touchscreen**, with a preloaded and updatable library of inserts and working forces. They allow electronic regulation of tightening time (from 0 to 5 s) and control of the punch stroke, ensuring precise stopping, especially suitable for soft materials such as fiberglass or printed circuit boards.

They are equipped with a **dual integrated safety system** with a distance sensor on the punch holder and operation by means of a dual electric safety pedal.



*4" touchscreen integrated in the foot pedal*

*Model 60 – Standard digital version, 6-ton capacity*

# CUSTOM-BUILT

We design and manufacture **custom-built hydraulic presses and insertion presses**, specifically developed to meet the requirements of each application and production process.

Our experience allows us to offer solutions with adapted capacities, dimensions, and technical configurations, ensuring maximum power, precision, and reliability in every operation.



## **PI-50E**

*Insertion and punching press for the manufacture of electrical panels.*

# HIDROGARNE



## SI-15E

*Insertion press designed for brake system assembly operations.*



## HB-35E

*Horizontal insertion press for riveting and chain fitting operations.*

# HIDROGARNE

Pol. Ind. Hostal Nou, 2  
25250 Bellpuig, Lleida, Spain

TEL. +34 973 320 666  
EMAIL: [info@hidrogarne.com](mailto:info@hidrogarne.com)